

Cross tables KT

Facts that impress in terms of quality, performance and price

- ▶ Coolant channel
- ▶ Dovetail guide adjustable
- ▶ Handwheels right, front and left - for model KT 120 only right and front
- ▶ Adjustable handwheel scaling with 0.05 mm scale

Technical specifications	KT 120	KT 179	KT 180	KT 210
A (Base width)	222 mm	274 mm	274 mm	280 mm
D (base length)	280 mm	340 mm	340 mm	362 mm
C (table length)	400 mm	500 mm	700 mm	730 mm
E (table width)	120 mm	180 mm	180 mm	210 mm
G (T-slot size)	10 mm	12 mm	12 mm	14 mm
Length x width x height	506 x 400 x 140 mm	748 x 483 x 155 mm	948 x 483 x 155 mm	1 060 x 538 x 185 mm
Weight	22 kg	40 kg	52 kg	84 kg
Travel				
X axis	220 mm	287 mm	480 mm	480 mm
Y axis	165 mm	167 mm	170 mm	210 mm
Max. load	40 kg	55 kg	55 kg	80 kg

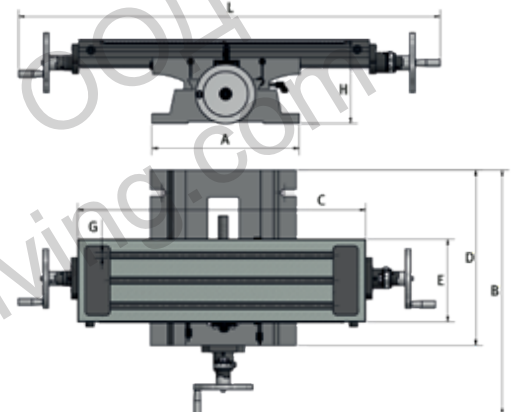

Cross tables KT	
KT 120	3356595
KT 179	3356596
KT 180	3356591
KT 210	3356600

Ташев Галвинг
www.tashev-galving.com